

ORTEC®

MÖBIUS™ Recycler

Condensing Liquid Nitrogen
HPGe Detector Cooling System



“All the advantages of Liquid Nitrogen cooling
without the need for frequent refilling.”

AMETEK®
ADVANCED MEASUREMENT TECHNOLOGY

Introduction

The ORTEC Möbius Recycler technology provides “tried and tested” LN₂ cooling of your HPGe detector in a system where LN₂ requires refilling approximately once every other year under normal, continuous operating conditions. This is achieved by the integration of a Sunpower® cryocooler and a specially designed 28 liter liquid nitrogen dewar.

The Möbius Recycler provides an excellent strategy for managing counting laboratories which have periodic power failures. A “smart” cooler controller senses when the Möbius is operating on an uninterrupted power supply (UPS) and automatically disables the cryocooler to minimize the power drain. This feature allows extended system operation when using smaller capacity UPS systems.

The LN₂ level monitor provides status regardless of mains power loss. While your laboratory may be in the dark, you won't be, when it comes to knowing the fill level of the LN₂ dewar.

ORTEC warrants the resolution performance for a new detector purchased with the Möbius Recycler to the detector's published performance specifications.

Key Benefits

- Ability to achieve LN₂ performance without the requirement for frequent system refilling – thus saving time, money and reducing hazardous material handling.
- During a loss of input power, the Möbius will continue cooling the detector as if it were a standard dewar.
- A large 28 liter dewar improves the duration for cooling during a power loss and helps extend the time between system refills.
- LN₂ level monitor can be remotely mounted and indicates LN₂ fill level, power consumption, and pressure levels allowing for proactive maintenance scheduling.
- Smart controller reduces UPS strain while allowing continued operation during a power outage.
- Integrates easily underneath standard lead shields with same footprint as standard dewar.
- Diagnostics and health parameters accessible by Windows PC.
- Flexibility with a wide range of cryostat and detector orientation including vertical options as well as side mounted configurations.
- Swap detectors as needed with any dipstick style Möbius or PopTop compatible Möbius-B.
- Excellent service and support built upon ORTEC's unique, fully vertical factory integration for design and quality of manufacturing.

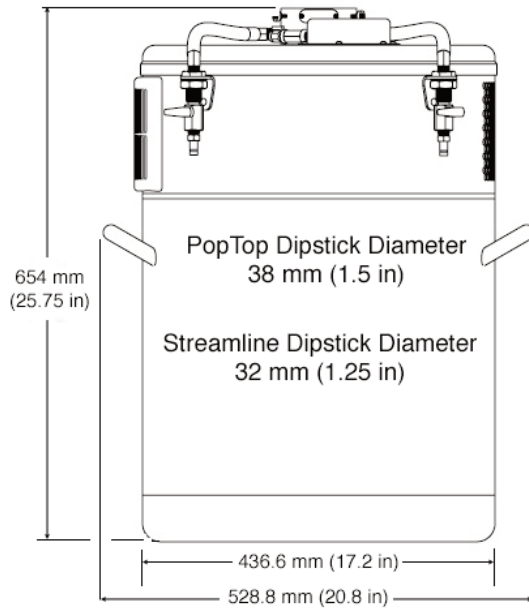

Möbius with Vertical or Horizontal Dipstick Cryostat

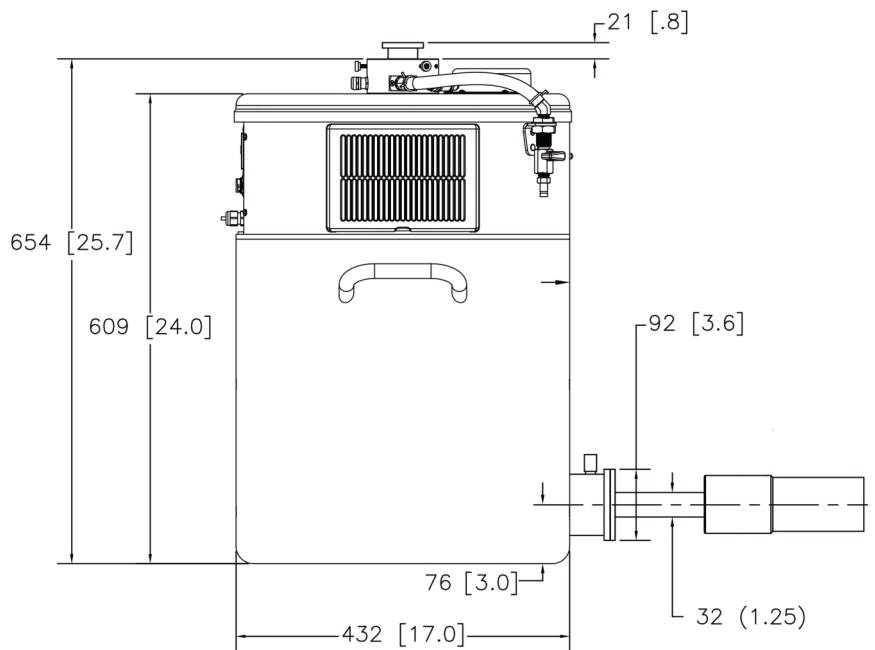

Möbius with Side-Looking Cryostat

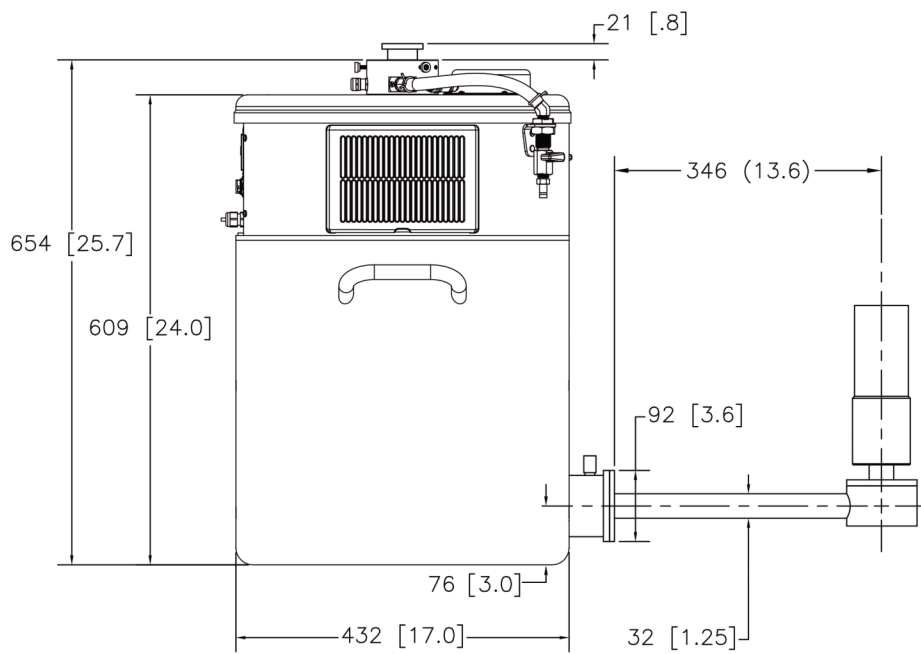

Möbius with J-style Cryostat

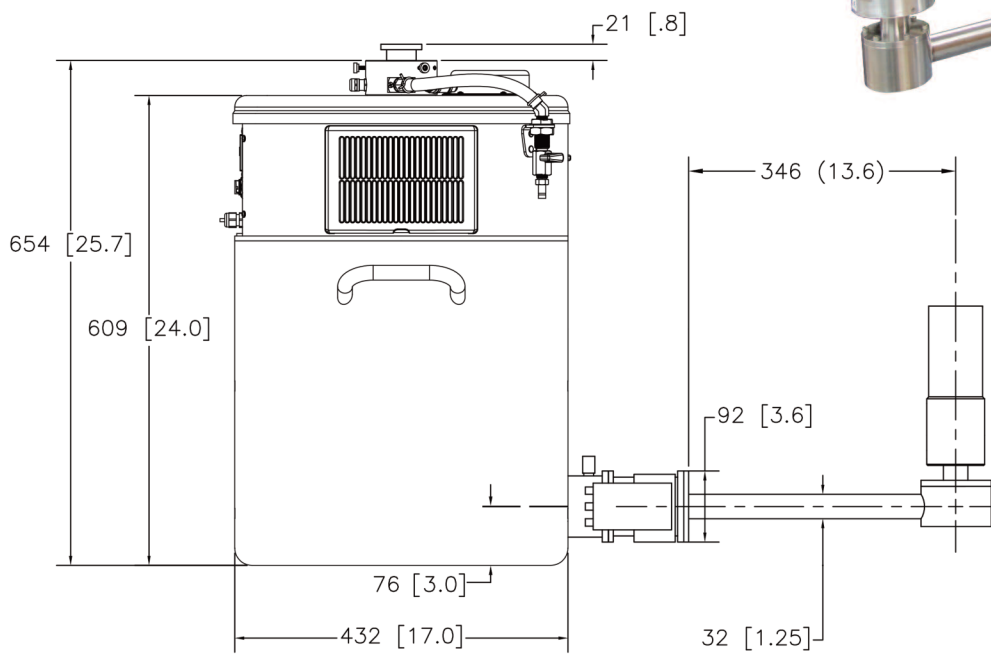

Möbius with HJ-style Cryostat with Remote Preamp

Performance Specifications

Refill Period	After the detector is cool and the LN ₂ is topped off, the Möbius system can run for 2 years or longer without filling. This is based on the sealing technology and assumes that it is operating in uninterrupted, steady state conditions.	
Maintenance	Easily removable, washable, air inlet filter. No other maintenance is required.	
Remote Display	The remote display attaches to the system with an umbilical cord and can be remotely mounted to improve visibility when the detector is placed in a lead shield. The display indicates LN ₂ fill height level, power consumption, pressure and overall status information. The user is warned when the dewar level drops below 70% full.	
Internal Controller	The control electronics and power supply are electrically isolated from the dewar, as is the cooler, and protected from LN ₂ spillage.	
Level Sensing	A capacitance level sensor provides a continuous measurement of the LN ₂ level from 0–100% full.	
Use with UPS Systems	The Möbius Recycler contains a small onboard computer which can receive an input in the event of power loss. The input causes the system to enter power saving mode and turn off the cryocooler. With the cryocooler turned off, the onboard computer and diagnostic electronics may be powered by a small UPS.	
LN₂ Holding Time (in case of power loss)	Approximately 7–10 days for a typical detector in a Streamline cryostat if Möbius is full. Approximately 4–7 days for a typical detector in a PopTop cryostat if Möbius is full.	
LN₂ Loss Rate	Approximately 3 liters per day when cooler is off. Operates as a standard dewar when power loss occurs.	
Spectroscopic Performance	When purchasing a new ORTEC detector with a Möbius, resolution is based on the detector data sheet.	Above 15 keV, no degradation of the detector warranted resolution. Below 15 keV, less than 10% of the warranted resolution.
	For existing ORTEC detector systems: when replacing an existing dewar or X-COOLER with a Möbius, resolution degradation is based on the existing detector performance.	It is expected that the detector will have similar performance compared to using a standard liquid nitrogen dewar. Some degradation may occur, depending on age and configuration of the detector.

Electrical and Mechanical Specifications

Dewar Capacity	28 Liters, excluding detector dipstick volume.
Cooler	AMETEK SUNPOWER with passive vibration dampening.
Auxiliary Cooling	Internal fan.
Audible Noise	Less than 60 dB (A) at 1 meter fully operational, below 30°C ambient.
Electrical Supply	100–240 V AC auto ranging from 120 to 240 V, 50 to 60 Hz.
Normal Power Consumption	125 W typical, 350 W maximum.
Dimensions	See drawings on previous pages.
Weight (excluding cryostat and detector)	63 lb (28.58 kg) empty. 113 lb (51.26 kg) full.
Operating Temperature	0 to 40°C. 20% to 90% relative humidity, non-condensing.
Warranty	2 years on Möbius unit only (excludes HPGe detector).
CE	Conforms to CE standards for radiated and conducted emissions, susceptibility and low-voltage power directives.
NRTL	Certification verifies, through OSHA-approved NRTL certification authority SGS, that the product meets U.S. electrical safety standards (UL/ANSI).

Ordering Information

Möbius with Dipstick Cryostat

MOBIUS-PT	Möbius Recycler for PopTop detector. Includes 1.5" (38.1 mm) diameter collar and CLAMP-1.50 to fit horizontal (CFG-PH4) or vertical (CFG-PV4) dipstick cryostat.
MOBIUS-ST	Möbius Recycler for Streamline detector. Includes 1.25" (31.75 mm) diameter collar and CLAMP-1.25 to fit horizontal (CFG-SH or CFG-N-SH) or vertical (CFG-SV) dipstick cryostat.
MOBIUS-PT-DET	MOBIUS-PT purchased in combination with any PopTop detector and CFG-PV4 vertical dipstick cryostat or CFG-PH4 horizontal dipstick cryostat.
MOBIUS-ST-DET	MOBIUS-ST purchased in combination with any Streamline detector and CFG-SV vertical dipstick cryostat, CFG-SH horizontal dipstick cryostat, or CFG-N-SH horizontal dipstick cryostat.

Möbius with Side-looking or J-style Cryostat

MOBIUS-B	Möbius Side-looking Recycler for purchase with a detector and J-style cryostat (CFG-HJ or CFG-SJ), or side-looking cryostat (CFG-SL). (Note, Möbius-B may only be purchased with a detector.)
CFG-PS4-MOBIUS-B	Möbius Side-looking Recycler for purchase as a stand alone for any PopTop detector.
CFG-PS4-MOBIUS-B-DET	CFG-PS4-MOBIUS-B-DET purchased in combination with any PopTop detector.

Options for Möbius with Dipstick Cryostat only

CFG-ADAPTOR	Collar adaptor allows use of 1.25" diameter dipstick cryostat.
CLAMP-1.25	Detector clamp for 1.25" dipstick diameter.
CLAMP-1.50	Detector clamp for 1.50" dipstick diameter.
MOBIUS	Möbius Recycler. Includes 1.5" (38.1 mm) diameter collar.



Notes

- 1) Other Möbius configurations are available as a special order. Contact the factory for more information.
- 2) Retrofit of an existing customer detector into MOBIUS-B requires the detector to be returned to the factory.

MÖBIUS

MÖBIUS

Specifications subject to change
102220

ORTEC[®]

www.ortec-online.com

Tel. (865) 482-4411 • Fax (865) 483-0396 • ortec.info@ametek.com
801 South Illinois Ave., Oak Ridge, TN 37830 U.S.A.
For International Office Locations, Visit Our Website

AMETEK[®]