

## DSS-MTC(20)-020

### Mercury Cadmium Telluride Solid State Detector

ELEMENTAL ANALYSIS
FLUORESCENCE
GRATINGS & OEM SPECTROMETERS
OPTICAL COMPONENTS
FORENSICS
PARTICLE CHARACTERIZATION
RAMAN
SPECTROSCOPIC ELLIPSOMETRY
SPR IMAGING

A mercury cadmium telluride photodiode, available with thermoelectric cooling, provides good spectral response in the near to mid-IR.

If you need a single point detector to measure signals in the near to mid-IR spectral region, the solid state MCT detector from HORIBA Scientific is an excellent choice. With high sensitivity ( $D^*$ ) and thermoelectric cooling, responsivity extends from 1000 nm to 5000 nm. This is one of a number of single point detectors available from HORIBA Scientific. Contact us for further information.

Used in conjunction with optically optimized housings, these detectors integrate seamlessly with HORIBA's extensive selection of monochromators. In addition, the SpectrAcq2 acquisition module allows for software integration with LabSpec, SynerJY, or LabVIEW. With all of the additional optical adapters available from HORIBA, a user can easily go from individual components to a complete spectroscopy solution.

### Features and Benefits

- Wide spectral responsivity from 2  $\mu\text{m}$  to 20  $\mu\text{m}$
- High sensitivity ( $D^* \sim 10^{10}$ )
- Down-looking liquid nitrogen detector housing

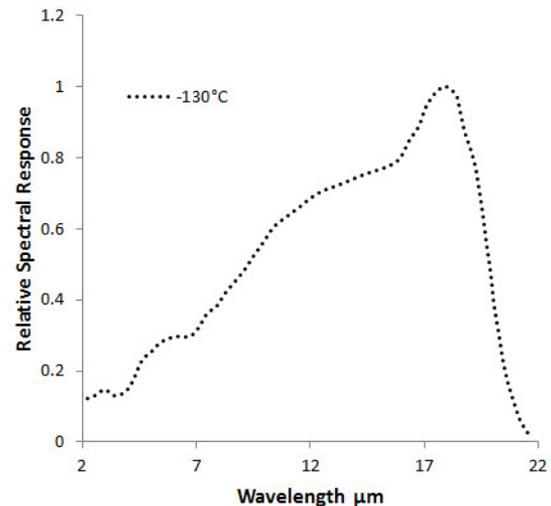

### Accessories

Various accessories are available for powering the detectors, optically coupling detectors to HORIBA monochromators, and data acquisition.

- Power supply for TE cooled detector, DSS-15V-TEP
- Mirror-based housing, 1427C
- BNC cable, J30646
- SpectrAcq2 data acquisition module
- SMA fiber adapter, DSS-SMA
- Dual 1427C housing adapter, J23078370
- Dual detector housing, J23079050
- BNC switchbox for dual detectors, SWB-AB



## Specifications

<b>Part number</b>	DSS-MCT(20)020L
<b>Detector type</b>	2.0 mm x 2.0 mm mercury cadmium telluride photoconductor
<b>Operating temperature (°C)</b>	-130°C liquid nitrogen cooled
<b>Operating wavelength (µm)</b>	2.0 – 20 µm
<b>Responsivity (V/W @ peak)</b>	10 <sup>5</sup> / 10 <sup>4</sup>
<b>NEP pk, (W/Hz<sup>1/2</sup>)</b>	< 3 x 10 <sup>-11</sup>
<b>Detectivity (D*)</b>	6.67 x 10 <sup>10</sup>
<b>Bandwidth (-3dB – Hz, typical)</b>	5 – 10 kHz
<b>Power requirements</b>	± 9 VDC to ± 15 VDC
<b>Connections</b>	BNC signal output. Shielded power cable terminated with a DB-9 connector directly couples the unit with the PS/TC-1 Low Noise Power Supply / Controller.

## Mechanical Dimensions

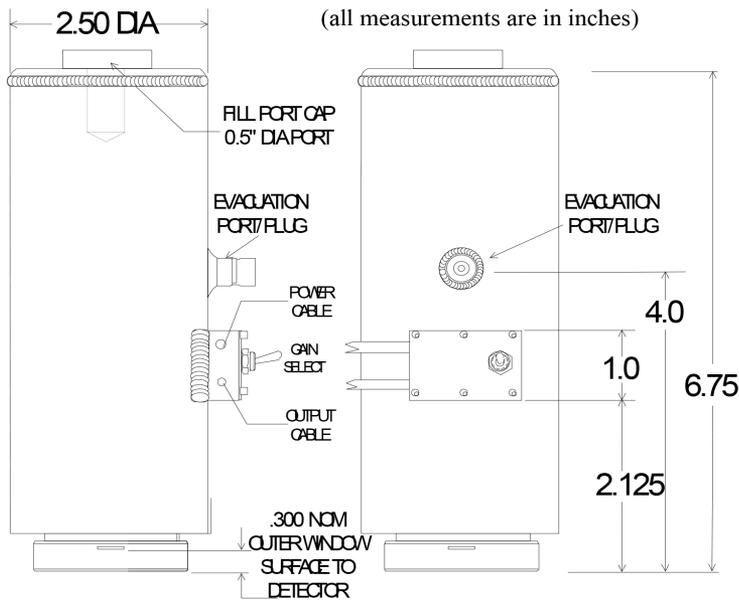

## Electrical Diagram

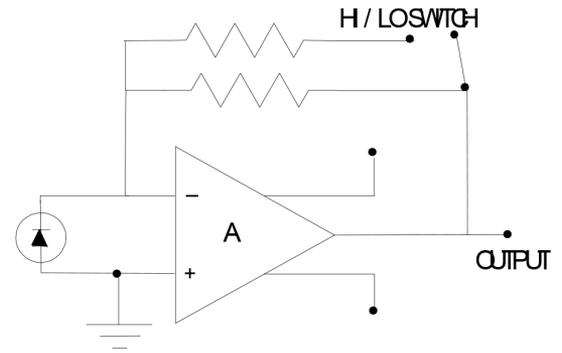

## DB-9 Pin Out Diagram

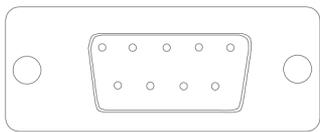

- |               |             |
|---------------|-------------|
| 1. No connect | 6. +V       |
| 2. No connect | 7. -V       |
| 3. No connect | 8. GND      |
| 4. No connect | 9. Case GND |
| 5. No connect |             |



**OPTICAL BUILDING BLOCKS**



**HORIBA**  
Scientific

[info.sci@horiba.com](mailto:info.sci@horiba.com) [www.horiba.com/opticalbuildingblocks](http://www.horiba.com/opticalbuildingblocks)

**USA:** +1 732 494 8660  
**UK:** +44 (0)20 8204 8142  
**China:** +86 (0)21 6289 6060

**France:** +33 (0)1 69 74 72 00  
**Italy:** +39 2 5760 3050  
**Brazil:** +55 (0)11 5545 1500

**Germany:** +49 (0)89 4623 17-0  
**Japan:** +81 (0)3 6206 4721  
**Other:** +1 732 494 8660